

### Homework-03 Due Friday Sept.-30, 2005 (prior to class)

1. Select a recent atmospheric pressure map (surface analysis at 12:00 UTC Sept.-24, 2005, say, or similar a few days later) of the United States and/or northern hemisphere. Identify major high and low pressure systems, estimate length scales, geostrophic wind velocities, and compare Rossby numbers for different features you may see on the map including hurricane Rita. What forces do you expect to be most relevant for the different features identified? How does relative vorticity compare to planetary vorticity for the different features? [10 pts.]
2. As depicted below (from Cushman-Roisin, 1994, p.59), a vertically uniform, but laterally sheared coastal current must climb a bottom escarpment. Assuming the jet velocity still vanishing offshore, determine the velocity profile and width of the jet downstream of the escarpment. What would happen if the downstream depth were only 100-m? [10 pts.]
3. Qualitatively, how would you need to modify your answer above if the jet was flowing in the north-south direction with a Coriolis parameter varying as a function of latitude? [5 pts.]

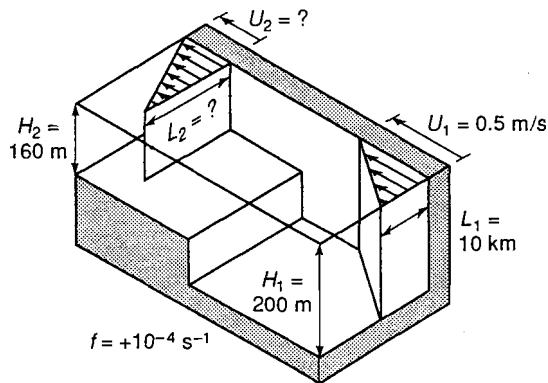

**Figure 4-8** A sheared coastal jet negotiating a bottom escarpment (Problem 4-6).